



AXN | HEAVY DUTY

**IT'S IN THE NAME.
IT'S IN THE PRODUCT.**

G-RAIL CHASSIS SLIDER

AXN ADVANTAGE

- ▶ AVAILABLE WITH BLACK E-COAT OR HOT-DIPPED GALVANIZED
- ▶ WEIGHT CAPACITIES UP TO 50,000 LBS FOR TANDEM AXLE
- ▶ AVAILABLE WITH DRUM OR DISC BRAKE AXLE
- ▶ DESIGNED FOR CHASSIS TRAILERS



G-RAIL DESIGN

- ▶ BOLT-ON AIR TANK BRACKET
- ▶ INTEGRATED MOUNTING BRACKET

BOLT-ON RAIL CLAMPING

- ▶ BOLT-ON SHIM UNDER RAIL CLIP ALLOWS FOR EASY SWAP AND REPLACEMENT

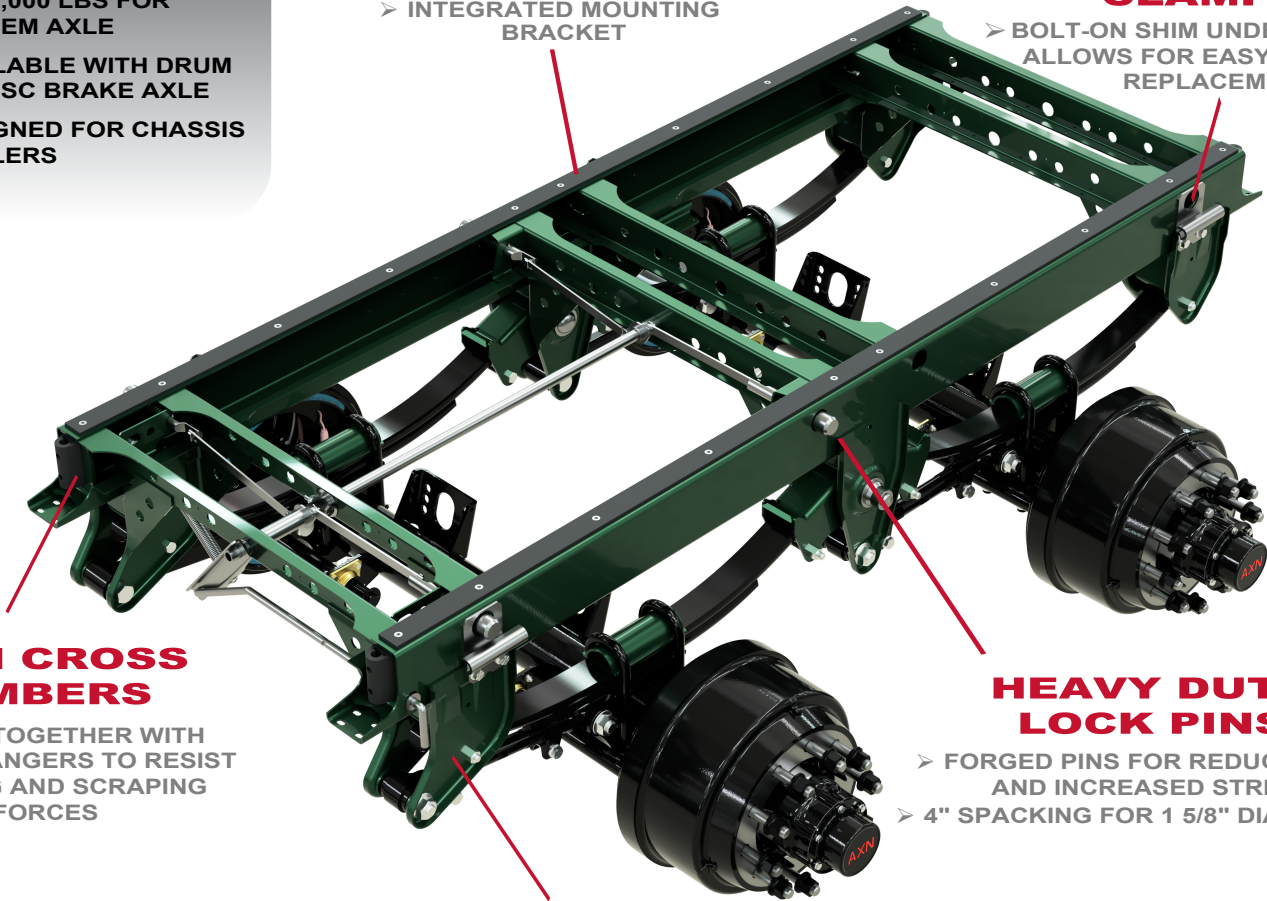

OPEN CROSS MEMBERS

- ▶ WORKS TOGETHER WITH WINGED HANGERS TO RESIST CURBING AND SCRAPING FORCES

HEAVY DUTY LOCK PINS

- ▶ FORGED PINS FOR REDUCED WEAR AND INCREASED STRENGTH
- ▶ 4" SPACKING FOR 1 5/8" DIAMETER PIN

WINGED HANGERS

- ▶ BUILT-IN DRAIN HOLES TO REDUCE CORROSION



AUTOMATIC TIRE INFLATION SYSTEM

Available, prepped with the Industry Leading P.S.I.® ATIS, featuring the patented ThermALERT® wheel-end heat sensing.



ISO 9001



TS 16949



DOT approved

AXN SALES CONTACTS

Southwest

Paul Coplen

pcoplen@axnheavyduty.com
512.905.4618

Upper Midwest

Brad Boehmer

bboehmer@axnheavyduty.com
502.592.2623

Northeast US & Canada

Marc Tarbay

mtarbay@axnheavyduty.com
502.554.3580

Southeast

David Norman

dnorman@axnheavyduty.com
502.341.4313

Inside Sales

Martez Reed

mreed@axnheavyduty.com
502.365.7174

Midwest

Andy Freeman

afreeman@axnheavyduty.com
502.432.4627



5534 National Turnpike
Louisville, KY 40214 • USA
502.749.3200

www.AXNHeavyDuty.com